



PowerCombi

12V/1200W 50A 120V, 12V/2000W 100A 120V

PURE SINE WAVE INVERTER/CHARGER



USER AND INSTALLATION MANUAL

10000015114/07

TABLE OF CONTENTS

1	SAFETY INSTRUCTIONS	3	4.4.3	DC wiring.....	11
1.1	General.....	3	4.4.4	Auxiliary DC output wiring.....	12
1.2	Warnings regarding the use of batteries	4	4.5	Things you need	12
1.3	Location	5	4.6	Connection example	13
1.4	Connections.....	5	4.7	Installation step-by-step.....	13
1.5	Warning regarding life support applications	5	4.8	PowerCombi Remote Panel (optional) .	14
2	GENERAL INFORMATION.....	6	4.9	Accessories connector (dry contacts)...	15
2.1	Intended use.....	6	4.9.1	Alarm output.....	15
2.2	Liability.....	6	4.9.2	Remote switch	15
2.3	Warranty	6	5	SETTINGS	16
2.4	Identification label.....	6	5.1	DIP switch setting	16
2.5	Correct disposal of this product.....	6	5.2	MasterBus settings	17
3	PRODUCT DESCRIPTION.....	7	6	OPERATING INSTRUCTIONS	18
3.1	Dimensions.....	7	6.1	General	18
3.2	Overview of AC side.....	7	6.2	Main switch	18
3.3	Overview of DC side.....	8	6.3	Status LEDs	18
3.4	Operating modes	8	6.4	3-step charge process	20
3.5	Remote control	9	6.5	Protections	21
4	INSTALLATION INSTRUCTIONS.....	10	6.6	Maintenance	22
4.1	Unpacking.....	10	6.7	Decommissioning.....	22
4.2	Location	10	6.8	Storage and transportation	22
4.3	Batteries.....	10	7	TROUBLESHOOTING.....	23
4.4	Wiring.....	11	8	TECHNICAL DATA.....	25
4.4.1	AC Safety grounding	11	8.1	Specifications.....	25
4.4.2	AC wiring	11	8.2	De-rating Curve.....	27

1 SAFETY INSTRUCTIONS

IMPORTANT SAFETY INSTRUCTIONS

SAVE THESE INSTRUCTIONS

1.1 General

1. This manual contains important safety and operating instructions for the following models:

Model	Part number
PowerCombi 12V/1200W-50A 120V	36211200
PowerCombi 12V/2000W-100A 120V	36212000

These models are further referred to as "PowerCombi Inverter/Charger".

2. CAUTION – To reduce risk of injury, the PowerCombi Inverter/Charger may only be used for charging Lead-acid type (flooded, Gel, AGM) or Mastervolt Lithium Ion rechargeable batteries and the supply of users attached to these batteries, in permanent systems. Other types of batteries may burst causing personal injury and damage.
3. Do not expose the PowerCombi Inverter/Charger to rain, snow, spray, moisture, excessive pollution, aggressive environments, ammonia, salt or condensing circumstances.
4. Use of an attachment not recommended or sold by Mastervolt may result in a risk of fire, electric shock, or injury to persons.
5. Except for making the electrical connections, the PowerCombi Inverter/Charger may not be opened. There are no serviceable parts inside the casing. Do not disassemble the PowerCombi Inverter/Charger; take it to a qualified serviceman when service or repair is required. Incorrect reassembly may result in a risk of electric shock or fire.
6. To reduce risk of electric shock, disconnect the PowerCombi Inverter/Charger from both AC and DC electrical system before attempting any maintenance or cleaning. Turning off controls will not reduce this risk. Be sure that third parties cannot reverse the measures taken.
7. The PowerCombi Inverter/Charger is not ignition protected. Avoid serious injury or death from fire or explosion. Do not install in compartment containing gasoline-fueled engines or gasoline tanks, or in areas where ignition protected equipment is required.
8. The PowerCombi Inverter/Charger is not to be used by children or persons with reduced physical, sensory or mental capabilities, or lack of experience and knowledge, unless they have been given supervision or instruction.
9. In case of fire, you must use the fire extinguisher which is appropriate for electrical equipment.

1.2 Warnings regarding the use of batteries

1. WARNING – RISK OF EXPLOSIVE GASES

- i. WORKING IN VICINITY OF A LEAD-ACID BATTERY IS DANGEROUS. BATTERIES GENERATE EXPLOSIVE GASES DURING NORMAL BATTERY OPERATION. FOR THIS REASON, IT IS OF UTMOST IMPORTANCE THAT EACH TIME BEFORE SERVICING THE POWERCOMBI INVERTER/CHARGER IN THE VICINITY OF THE BATTERY, YOU READ THIS MANUAL AND FOLLOW THE INSTRUCTIONS EXACTLY.
- ii. To reduce risk of battery explosion, follow these instructions and those published by battery manufacturer and manufacturer of any unit you intend to use in vicinity of battery. Review cautionary marking on these products and on engine.

2. PERSONAL PRECAUTIONS

- i. Someone should be within range of your voice or close enough to come to your aid when you work near a lead-acid battery.
- ii. Have plenty of fresh water and soap nearby in case battery acid contacts skin, clothing, or eyes.
- iii. Wear complete eye protection and clothing protection. Avoid touching eyes while working near battery.
- iv. If battery acid contacts skin or clothing, wash immediately with soap and water. If acid enters eye, immediately flood eye with running cold water for at least 10 min and get medical attention immediately.
- v. NEVER smoke or allow a spark or flame in vicinity of battery or engine.
- vi. Do not short circuit battery! Be extra cautious to reduce risk of dropping a metal tool onto battery. It might spark or short-circuit battery or other electrical part that may cause explosion.
- vii. Remove personal metal items such as rings, bracelets, necklaces, and watches when working with a lead-acid battery. A lead-acid battery can produce a short-circuit current high enough to weld a ring or the like to metal, causing a severe burn.
- viii. NEVER charge a frozen battery.
- ix. If necessary to remove battery from a vessel or vehicle, always remove grounded terminal from battery first. Make sure all accessories in the vessels or vehicle are off, so as not to cause an arc.
- x. Be sure that the area around battery is well ventilated.
- xi. Clean battery terminals. Be careful to keep corrosion from coming in contact with eyes.
- xii. Study all battery manufacturer's specific precautions such as removing or not removing cell caps while charging and recommended rates of charge.
- xiii. Add distilled water in each cell until battery acid reaches level specified by battery manufacturer. This helps purge excessive gas from cells. Do not overfill. For a battery without cell caps (e.g. AGM, Gel or Li-ion batteries), carefully follow manufacturer's recharging instructions.
- xiv. A battery is heavy! It may become a projectile if it is involved in an accident! Ensure adequate and secure mounting and always use suitable handling equipment for transportation.

1.3 Location

1. POWERCOMBI INVERTER/ CHARGER LOCATION

- i. Locate the PowerCombi Inverter/Charger away from battery in a separate, well ventilated compartment.
- ii. Never place marine converter or inverter directly above battery; gases from battery will corrode and damage marine converter.
- iii. Never allow battery acid to drip on the PowerCombi Inverter/Charger when reading gravity or filling battery.
- iv. Do not operate the PowerCombi Inverter/Charger in a closed-in area or restrict ventilation in any way. To reduce risk of fire hazard, do not cover or obstruct the ventilation openings.

1.4 Connections

1. DC CONNECTION PRECAUTIONS

- i. Connect and disconnect DC output connections only after setting any switches of the PowerCombi Inverter/Charger to off position and removing AC connections or opening AC disconnect switch.
- ii. Short circuiting or reversing polarity will lead to serious damage to batteries, the PowerCombi Inverter/Charger, wiring as well as accessories. Fuses cannot prevent damage caused by reversed polarity and the warranty will be void.

2. EXTERNAL CONNECTIONS TO CHARGER SHALL COMPLY WITH THE UNITED STATES COAST GUARD ELECTRICAL REGULATIONS (33CFR183, SUB PART I).

3. GROUNDING INSTRUCTIONS – The PowerCombi Inverter/Charger should be connected to a grounded, metal, permanent wiring system; or an equipment-grounding conductor should be run with circuit conductors and connected to equipment-grounding terminal or lead on unit. Connections to the PowerCombi Inverter/Charger should comply with all local codes and ordinances.

1.5 Warning regarding life support applications

Mastervolt products are not designed to be used as component of medical equipment, unless negotiated in the form of a written agreement between customer and/or manufacturer and Mastervolt. Such agreement will require the equipment manufacturer either to contract additional reliability testing of the Mastervolt parts and/or to commit to undertake such testing as a part of the manufacturing process. Furthermore, the manufacturer must agree to indemnify and not hold Mastervolt responsible for any claims arising from the use of the Mastervolt parts in the life support equipment.

2 GENERAL INFORMATION

2.1 Intended use

Use the PowerCombi Inverter/Charger only observing the instructions in this user and installation manual.

2.2 Liability

Mastervolt can accept no liability for:

- Consequential damage resulting from the use of the PowerCombi Inverter/Charger;
- Possible errors in the included manual and the consequences of these;
- Use that is inconsistent with the purpose of the product.

Disclaimer: Our products are subject to continual development and improvement. Therefore, additions or modifications to the products may cause changes to the technical data and functional specifications. No rights can be derived from this document. Please consult our most current Terms & Conditions of Sale.

2.3 Warranty

Mastervolt assures the product warranty of the PowerCombi Inverter/Charger during two years after purchase, on the condition that the product is installed and used according to the instructions in this manual. Installation or use not according to these instructions may result in under performance, damage or failure of the product and may void this warranty. The warranty is limited to the cost of repair and/or replacement of the product. Costs of labor or shipping are not covered by this warranty.

2.4 Identification label



Part and Serial number

Important information required for service or maintenance can be derived from the identification label. The identification label is located at the rear side of the PowerCombi Inverter/Charger.



CAUTION!

Never remove the identification label. This will void the warranty.

Figure 1: Identification label

2.5 Correct disposal of this product



This product is designed and manufactured with high quality materials and components, which can be recycled and reused. Please be informed about the local separate collection system for electrical and electronic products. Please act according to your local rules and do not dispose of your old products with your normal household waste. The correct disposal of your old product will help prevent potential negative consequences to the environment and human health.

3 PRODUCT DESCRIPTION

3.1 Dimensions

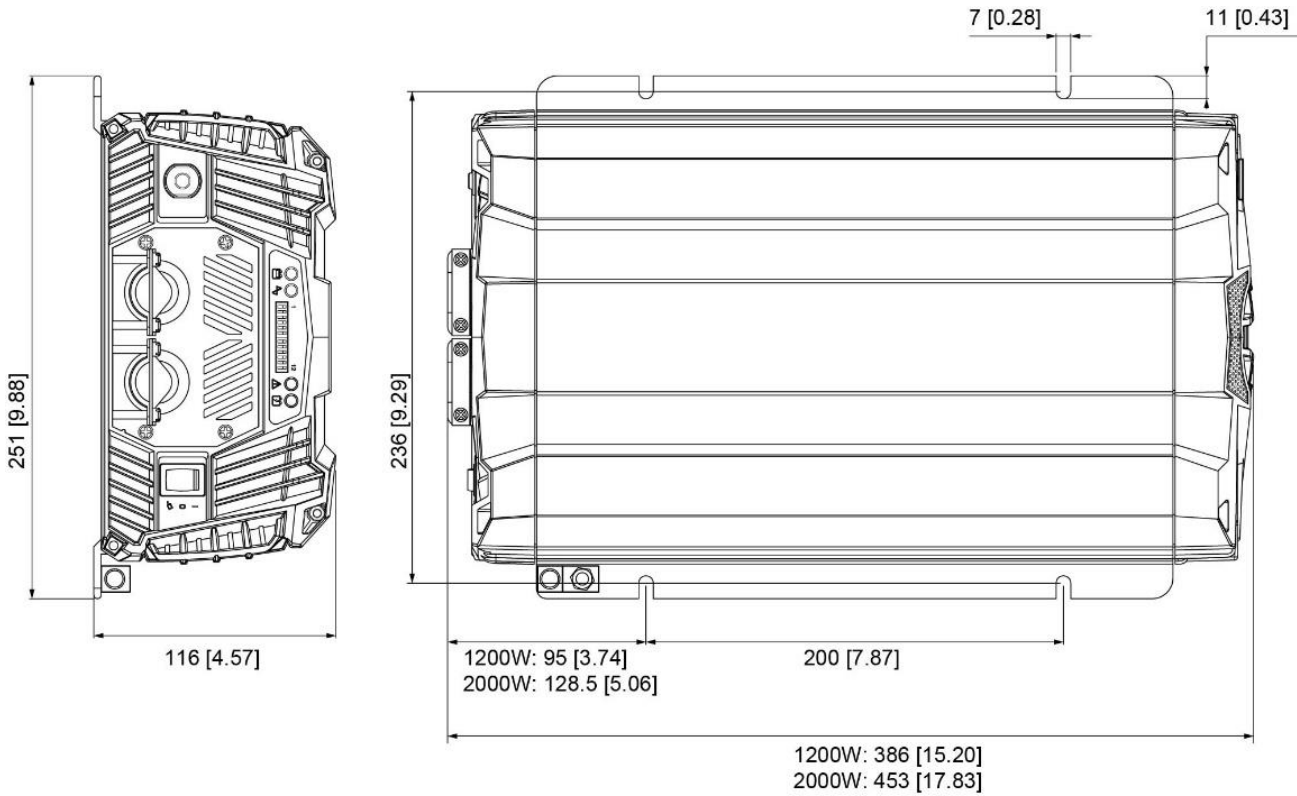

Figure 2: Dimensions PowerCombi in mm [inch]

3.2 Overview of AC side

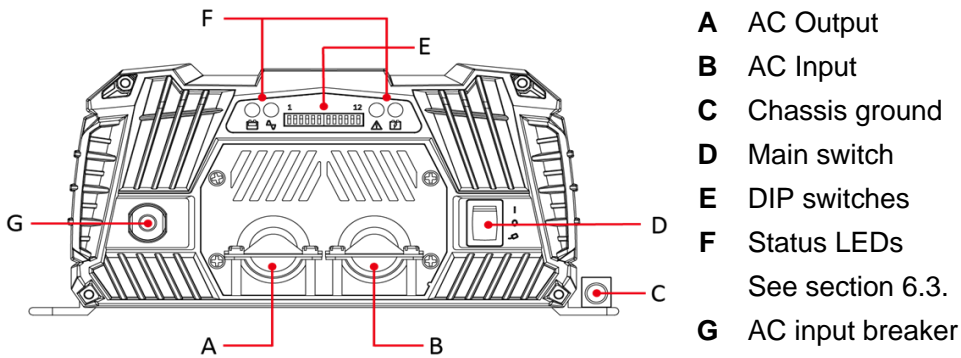

Figure 3: AC side – exterior

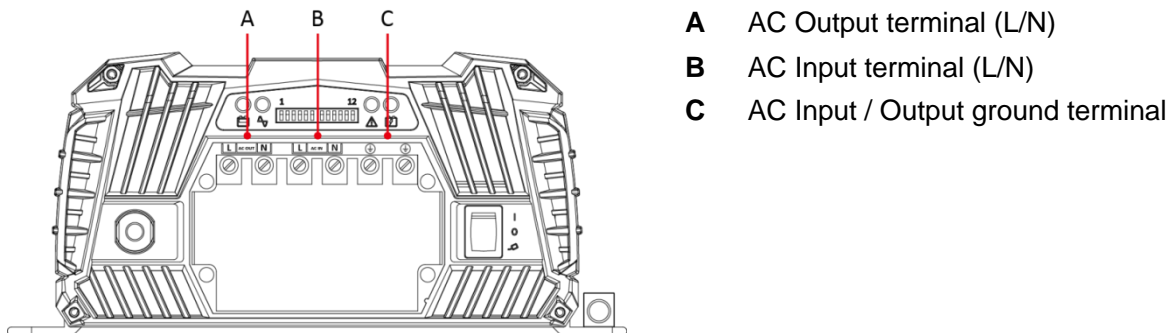
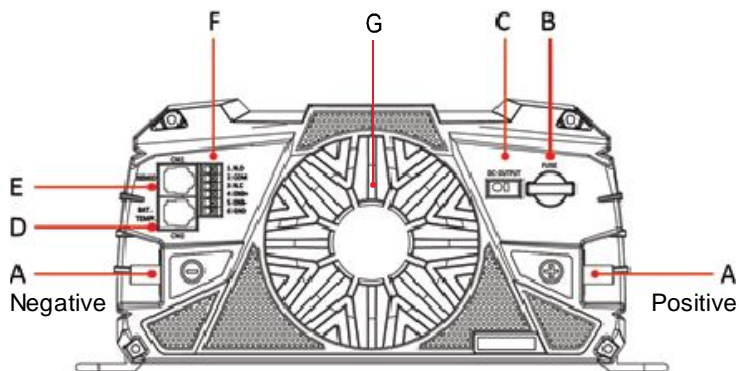

Figure 4: AC side – interior

3.3 Overview of DC side



- A** DC input connector
- B** Auxiliary DC output Fuse (20A)
- C** Auxiliary DC output
- D** RJ11 Battery Temp. sensor port (optional, 41500700)
- E** Remote port (RJ11)
- F** Dry contacts; Remote switch input and Alarm output
- G** Fan

Figure 5: DC side

3.4 Operating modes

• Inverter mode

When there is no external AC power available, the inverter provides AC power on the AC outputs. If energy saving mode is enabled, battery power consumption will be reduced when there is no (i.e. less than 20W for 10 seconds) load on AC OUT. Please note that small loads such as wifi routers, satellite receivers or digital clocks are most likely not to work in this mode.

• Charger mode

When external AC power is available on the AC input, the battery will be charged and the AC output is supplied by the external power.

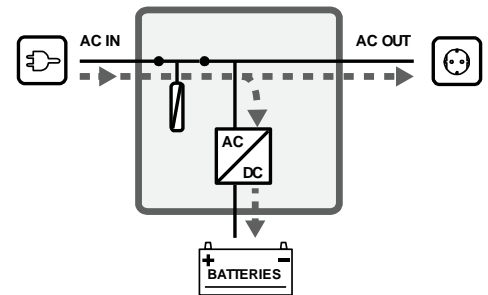

• Power sharing mode

If the available power at the AC IN is limited, and the load connected to AC OUT increases, the external AC circuit breaker may trip if nothing is done. To avoid this, the unit can automatically reduce the battery charger output, and thus the AC power consumption.

The Power Sharing level (adjustable from the PowerCombi Remote Panel or a laptop/notebook connected via the MasterBus PowerCombi Interface) should be set to match the value of the external circuit breaker, which protects AC IN.

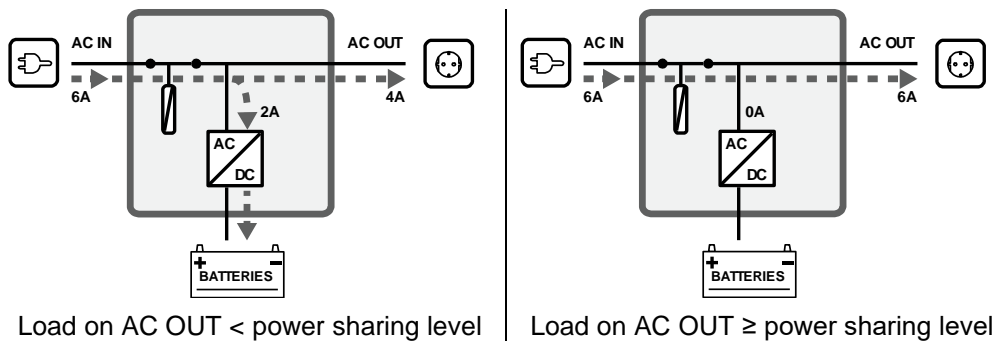

- **AC IN support mode**

If the demand for AC power still increases, the external AC circuit breaker may still trip if nothing is done. This problem can be solved by the AC IN support mode. If the total demand for energy exceeds the maximum external power supply, energy can be added to AC OUT by means of the inverter. This means that the inverter adds energy from the batteries, in parallel with the external power source.

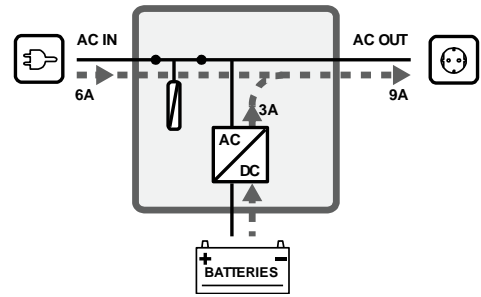

Note: Under no circumstances AC power from the inverter can be fed back into the AC grid. Different countries have different regulations regarding AC sources operating in parallel with the AC grid. This may mean that in some situations AC IN support mode is not allowed! Familiarize yourself with local regulations on this issue.

3.5 Remote control

Mastervolt offers several possibilities for remote monitoring and control of the PowerCombi Inverter/Charger. See www.mastervolt.com for all available options.

- PowerCombi Remote Control (77010700).
- MasterBus PowerCombi Interface (77032900); enables configuration (of voltage levels for example) from a notebook/laptop which is obligatory if the installation comprises the Mastervolt MLI battery.

4 INSTALLATION INSTRUCTIONS

During installation and commissioning of the unit, the Safety Instructions are applicable at all times. See chapter 1 of this manual.

4.1 Unpacking

The delivery includes:

- PowerCombi Inverter/Charger
- Two cable lugs for the DC input connection
- User and installation manual and accessory labels.

After unpacking, check the contents for possible damage. Do not use the PowerCombi Inverter/Charger if it has received a sharp blow, been dropped, or otherwise damaged in any way. If in doubt, Contact your supplier or Mastervolt.

Check from the identification label (see section 2.4) whether the battery voltage is the same as the nominal output voltage of the PowerCombi Inverter/Charger (e.g. 12V battery set for a 12V battery charger). Also check that the AC output voltage and output power of the PowerCombi Inverter/Charger complies with your system and loads.

4.2 Location

- The PowerCombi Inverter/Charger is designed for indoor use only (IP 21).
- Ambient temperature: 14°F to 140°F [-10°C to 60°C], power derating above 104°F [40°C].
- Humidity max 93%, non-condensing
- The PowerCombi Inverter/Charger requires a minimum of 4" of clearance on every side to ensure safety and proper ventilation.
- If the PowerCombi Inverter/Charger is installed in the immediate vicinity of living areas, take into account that the fan of the PowerCombi Inverter/Charger can produce noise when operating.
- Although the PowerCombi Inverter/Charger fully complies with all applicable EMC limits, it may still cause harmful interference to radio communication equipment. If such interference appears, it is recommended to increase the separation between the PowerCombi Inverter/Charger and the equipment, to relocate the receiving antenna or to connect the equipment to a circuit different from that to which the PowerCombi Inverter/Charger is connected.
- The PowerCombi Inverter/Charger can be mounted horizontally as well as vertically (see section 4.7 on page 13).

4.3 Batteries

Model	Recommended battery capacity
12V/1200W-50A	120 – 360 Ah
12V/2000W-100A	200 – 600 Ah

Data based on Mastervolt Gel batteries. If other batteries are used, make sure the manufacturer's recommendations are met.

4.4 Wiring



WARNING!

Make sure that all wiring is properly installed, in good condition and correctly sized to match the current ratings of the PowerCombi Inverter/Charger. The wire sizes stated in this manual are only guidelines. Always comply with all local rules and regulations.

4.4.1 AC Safety grounding

The ground connection (item C in Figure 3) accepts CU/AL conductors from #14 to #2 AWG (2.5 to 35 mm²).



WARNING!

For safety reasons Ground Fault Circuit Interrupters (GFCIs), also known as Residual Current Devices (RCDs), must be integrated in the AC input and AC output of the PowerCombi Inverter/Charger. Always comply with all local rules and regulations.



WARNING!

The ground wire offers protection only if the case of the unit is connected to the safety ground. Connect the chassis ground terminal to the hull or the chassis of the boat or vehicle that this PowerCombi Inverter/Charger is equipped on.

In inverter state, the AC OUT neutral (N) is automatically connected to the AC ground. In charger state, i.e. when external AC power is available, the PowerCombi Inverter/Charger disconnects the neutral AC from the AC ground. Refer to local regulations on these issues!

4.4.2 AC wiring



WARNING!

On first connecting to power, make sure the PowerCombi Inverter/Charger is in a well-ventilated area as it might spark.

For a safe installation the correct wire cross section must be applied. Do not use a cross section that is smaller than indicated. Recommended cross section for the AC wiring:

Model	AC cable cross section
12V/1200W-50A	10AWG [6mm ²]
12V/2000W-100A	10AWG [6mm ²]

Recommended wire colors (refer to local rules):

Wire color	Meaning	Must be connected to:
Black	Hot or Line	L
White	Neutral	N
Green	Earth	PE / GND

4.4.3 DC wiring

Keep in mind that high current will pass through the DC wiring. Keep the cable length as short as possible, this will keep the system efficiency as high as possible.

Model	DC cable cross section < 6ft [2m]
12V/1200W-50A	2AWG [35mm ²]
12V/2000W-100A	2/0AWG [70mm ²]

Recommended wire colors (refer to local rules):

Wire color	Meaning	Connect to:
Red	Positive	+ (POS)
Black or yellow	Negative	- (NEG)

Run the cables next to each other to limit the electromagnetic field around the cables. The negative cable should be connected directly to the negative post of the battery bank or the ground side of a current shunt. Do not use the chassis frame as the negative conductor. The positive battery cable must be fused and connected to the positive post of the battery bank. Use a fuse that matches the applied wire size. The fuse with fuse-holder is available from your local Mastervolt distributor.

4.4.4 Auxiliary DC output wiring

The Auxiliary DC output can be used for charging a small second battery set like a starter battery. When enabled, this output is active when external AC power is available on AC IN. The maximum current is 20A. Use 10 to 12 AWG wire for the connection.

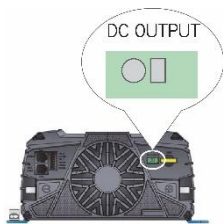

- Step 1. Connect the negative of the 2nd battery to the minus of the main battery.
- Step 2. Connect the positive of the 2nd battery to the auxiliary DC OUTPUT of the PowerCombi Inverter/Charger. Place a small screwdriver in the rectangular opening and drive down to open up the clamp. Place the wire in the round opening and remove the screwdriver.
- Step 3. Integrate a 20A slow blow fuse in the plus cable.

The Auxiliary DC output fuse protects the 2nd battery from overcharging.

Figure 6: Auxiliary DC Output connector block

4.5 Things you need

Make sure you have all the parts you need to install a PowerCombi Inverter/Charger:

- PowerCombi Inverter/Charger (included).
- Optional: Battery temperature sensor with cable and plug (not included).
Note: Lithium-ion batteries require no temperature sensor as they have built-in intelligence that monitors the internal temperature.
- DC cables to connect the PowerCombi Inverter/Charger to the batteries and common negative. See section 4.4.3 for specifications.
- DC fuse holder with a DC fuse, to be integrated in the positive DC cable.
- Screws/bolts (\varnothing 1/4" / 6mm) with plugs to mount the PowerCombi Inverter/Charger to a surface. Use mounting materials which are suited to carry the weight of the PowerCombi Inverter/Charger.
- AC cable to connect the AC input to an AC power source. See section 4.4.1 for specifications.
- Batteries. See section 4.3 for specifications.
- Appropriate and reliable cable terminals, cable lugs, battery terminals and cord end terminals.

We recommend as a minimum tool kit:

- Socket wrench to fix the main DC cables (1/2" / 13mm).
- Socket wrench to fix the Safety ground connection (3/8" / 10mm).
- Flat blade screwdriver to fix the screw terminals of the AC wiring.
- Tools to fix the screws / bolts (\varnothing 1/4" / 6mm) with plugs to mount the PowerCombi Inverter/Charger to a surface.
- Philips screwdriver to open the connection compartment.

4.6 Connection example

This schematic illustrates the general placement of the PowerCombi Inverter/Charger in a circuit. It is not meant to provide detailed wiring instructions for any particular electrical installation.

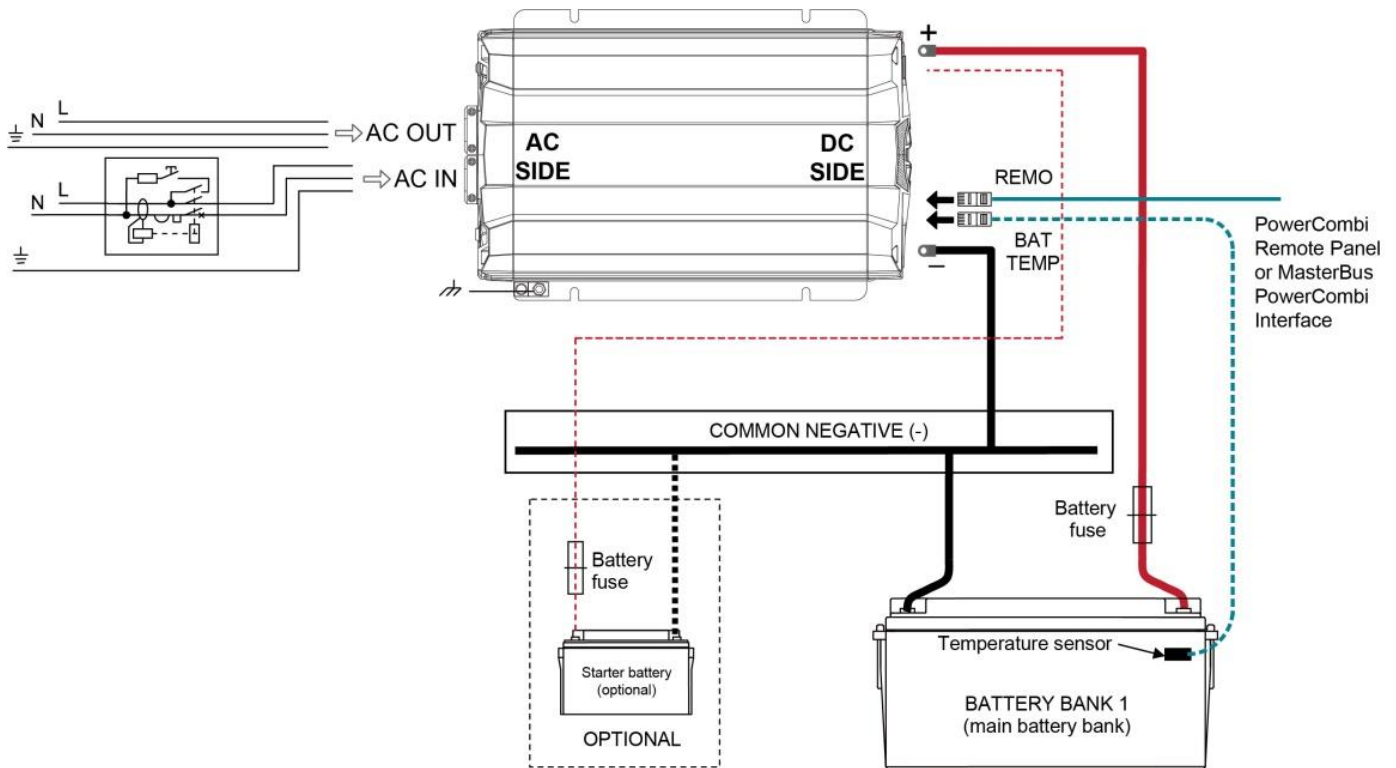

Figure 7: Installation drawing PowerCombi Inverter/Charger

4.7 Installation step-by-step

Step 1. Disconnect power supplies.

Step 2. Mount the PowerCombi with four screws to a solid surface.

Ceiling Mount

Use the screws to mount the product on the wall, and the product mounting requirement is as follows: the mounting height from the ground to product requires at least 28" [70cm].

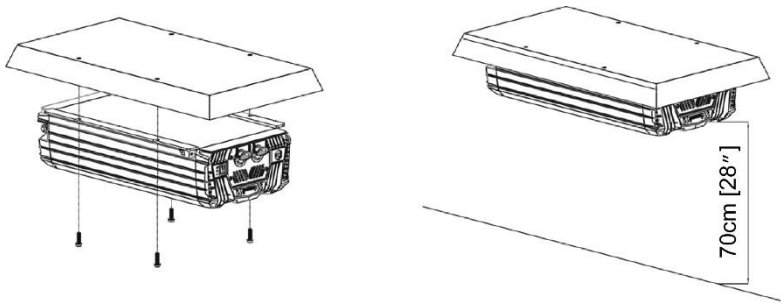

Wall Mount

1. Use the screws to mount the Drip shield and the product on the wall.
2. Please make sure the height from the ground to product at least 28" [70cm].
The bulkhead size requires at least 4" (100mm) clearance each side of the inverter.

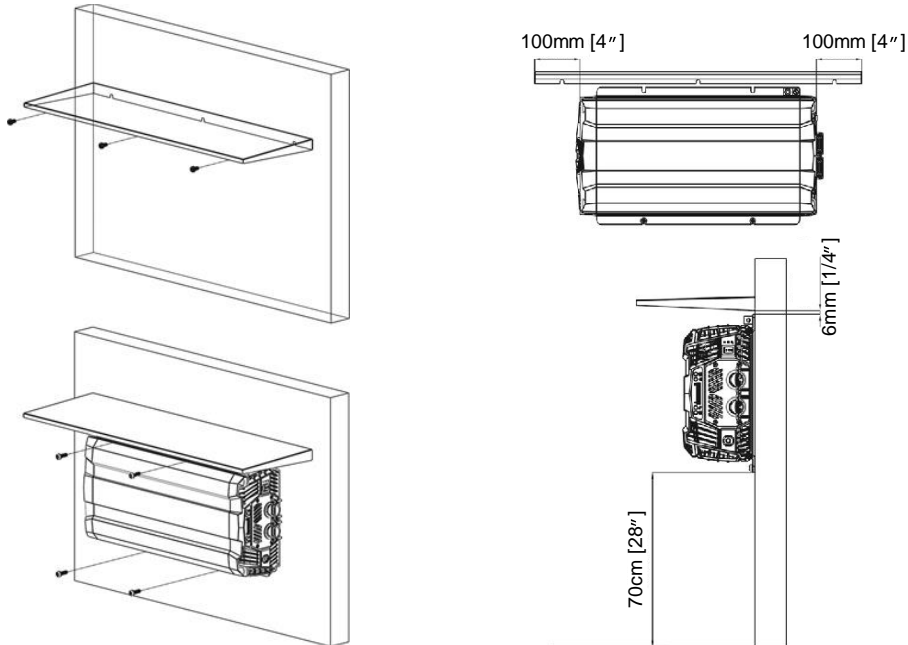

- Step 3.** Connect the chassis ground terminal to the central grounding point.
- Step 4.** Connect the AC wiring to the screw terminals. Fasten the cables with a clip.
- Step 5.** Integrate a fuse holder in the positive battery wire but do not place the fuse yet!
- Step 6.** Fit crimp-on ring terminals (5/16" / M8) to the DC cables. Connect the DC cabling of the battery bank; positive to +, negative to – .
- Step 7.** Optional: Attach the battery temperature sensor to the casing of the battery bank. Then plug the RJ11 temperature sensor cable into the Battery Temp. sensor port (item D in Figure 5).
- Step 8.** Use a small screwdriver to change DIP switch settings. See section 5.1.
- Step 9.** Option: connect external alarm or remote switch input. See section 4.9.
- Step 10.** Check all wiring. If all wiring is OK: Place the inverter fuse.



WARNING!

When the fuse is placed, internal capacitors may cause a spark. This is normal

- Step 11.** Close the connection compartment and fix the screws at the bottom.
- Step 12.** Switch on the PowerCombi Inverter/Charger.
- Step 13.** Optional: Set the desired output voltage and other configuration settings from the PowerCombi Remote Panel or laptop/notebook connected via the MasterBus PowerCombi Interface, see chapter 5.

4.8 PowerCombi Remote Panel (optional)

Optionally the PowerCombi Remote Panel is connected to the RJ-11 remote port (REMO) on the DC input side. Before using the PowerCombi Remote Panel, make sure the main switch is in the Remote (=) position before startup.

4.9 Accessories connector (dry contacts)

The 6 pin terminal (item F in Figure 5) at the DC side offers the following contacts:

Alarm contact (maximum load 250VAC / 24VDC / 1A)	1	N.O	Normally Open
	2	COM	Common
	3	N.C	Normally Closed
Remote control	4	ENB+	Enable +
	5	ENB-	Enable -
	6	GND	Ground (same polarity with negative battery input)

Use 20 ~ 24 #AWG [0.50 ~ 0.20 mm²] wire to connect the remote control terminals.

4.9.1 Alarm output

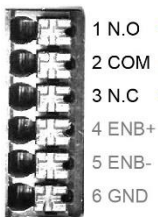

The upper three contacts of the accessories connector can be used to control external equipment, like an alarm or light, to indicate a PowerCombi Inverter/Charger fault (input under/over voltage, output short circuit/overload, over/under temperature). The alarm outputs support *Normally Closed* and *Normally Open* systems.

No fault detected: N-Closed and Common connected

Fault detected: N-Open and Common connected (PowerCombi Inverter/Charger off)

4.9.2 Remote switch

The lower three contacts of the accessories connector can be used to connect a remote switch that mimics the main switch. Make sure the main switch is at Remote (=) position.

- When the remote switch requires no power source, connect one side of the switch to contact 5 (ENB-) and the other to contact 6 (GND).
- When the remote switch requires a power source, connect one side of the switch to contact 4 (ENB+) and the other to positive DC power. If this power is not from the main battery bank, make sure that the voltage level equals the voltage level of the system.

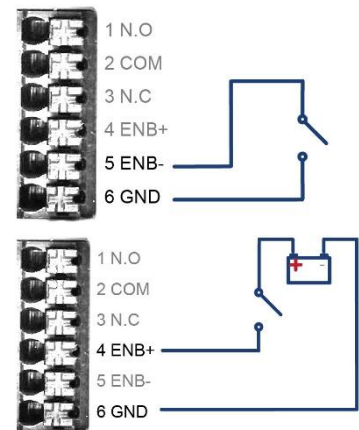

5 SETTINGS

Adjustment of the settings of the PowerCombi Inverter/Charger can be made in three different ways:

- By means of DIP switches.
- From the PowerCombi Remote Panel, see the PowerCombi Remote Panel user manual.
- From a laptop/notebook connected via the MasterBus PowerCombi Interface.

CAUTION!



Invalid settings of the PowerCombi Inverter/Charger can cause serious damage to your batteries and/or the connected load! Adjustment of settings must be carried out by authorized personnel only.

5.1 DIP switch setting

Open the connection compartment to access the DIP switches S1 to S12 (item E in Figure 3) and use a small screwdriver to carefully set the required settings.



WARNING!

Never open the connection compartment when the PowerCombi Inverter/Charger is connected to a power source.

Output Voltage	S1	S2
100V	OFF	OFF
110V	ON	OFF
115V	OFF	ON
120V	ON	ON

Frequency	S3
50HZ	OFF
60HZ (default)	ON

AC Input Current Limit	S4	S5	S6
3A	OFF	OFF	OFF
6A	ON	OFF	OFF
9A	OFF	ON	OFF
12A	ON	ON	OFF
15A (default)	OFF	OFF	ON
20A	ON	OFF	ON
25A	OFF	ON	ON
30A	ON	ON	ON

Battery Type	S7	S8
GEL	OFF	OFF
Flooded (default)	ON	OFF
AGM	OFF	ON
Custom*	ON	ON

* When using a Mastervolt MLI Lithium Ion battery, select the Custom type and set the voltage levels in MasterAdjust. Note that this requires the PowerCombi Interface. See also chapter 5.2.

Max. Charger Current (%)	S9	S10
25%	OFF	OFF
50%	ON	OFF
75%	OFF	ON
100% (default)	ON	ON

See chapter 8.1 on page 25 for charge profile voltages.

Auxiliary DC output	S11
OFF (default)	OFF
ON	ON

Energy Saving mode	S12
OFF (default)	OFF
ON	ON

5.2 MasterBus settings

MasterBus is a CAN based data network for communication between Mastervolt devices. When the PowerCombi Inverter/Charger is connected, open MasterAdjust on a Windows laptop or notebook connected to the MasterBus network. MasterAdjust software is available as free to download software on the Mastervolt website: www.mastervolt.com. This tool runs on a Windows laptop or notebook connected via the MasterBus PowerCombi Interface.

How to set the values for a Mastervolt MLI battery

1. Open MasterAdjust.
2. Select the PowerCombi Inverter/Charger.
3. Go to the **Configuration** tab.
4. As **Battery type**, select **Custom** from the drop-down list.
5. Enter the following values:

Bulk voltage	14.25 V
Max bulk time	480 min
Absorption voltage	14.25 V
Max abs. time	240 min
Float voltage	13.50 V

Note: Please refer to the manual of the MLI-Ultra for more information about the configuration and installation of an MLI-Ultra battery.

6 OPERATING INSTRUCTIONS

6.1 General



WARNING!

The PowerCombi Inverter/Charger must be properly assembled in accordance with the Installation Instructions before it is used.

6.2 Main switch

The main switch on the PowerCombi Inverter/Charger has three positions: On (—), Off (●) and Remote (⇒).



WARNING!

Switching to Off or Remote does not cut off the connection to the batteries or the AC source. This means that voltages are still present inside the apparatus!

- Notes:**
- Provided that the main switch is not in the Remote position, the PowerCombi Inverter/Charger will switch on when a battery is connected and external AC power is available, even if the switch is in the off position!
 - If external AC power is unavailable or outside the specified limits, the PowerCombi Inverter/Charger operates as an inverter.
 - When using a PowerCombi Remote Control, switch to Remote.

6.3 Status LEDs

Battery Input voltage indicator

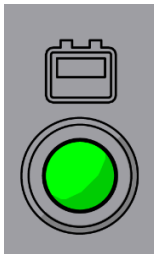

LED status	Voltage
Red	< 11.0 V or >15.5 V
Orange	11.0~ 11.5 V or 15.0 ~ 15.5 V
Green	11.5 ~ 15.0 V

Output Load indicator

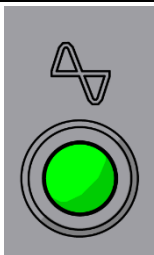

LED status	Voltage
Red	> 115%
Orange	100 - 115%
Green	0 - 100%

Charger State indicator

LED status	Meaning
Off	Inverter mode
—————	Float Mode
Green	
—————	Absorption Mode
Orange	
— — — — —	Bulk mode
Orange, slow blinking	

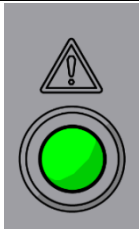
Alarm indicator

LED status	Meaning	What to do?
—————	Power OK	Normal operation
Green		
— — — — —	Internal temp. too high	1. Improve ventilation. Make sure ventilation openings in the unit are not obstructed. 2. Reduce ambient temperature. 3. Reduce load.
Green, slow blinking		
— — — — —	Internal temp. too low	Increase ambient temperature.
Green, fast blinking		
—————	Overload / short circuit protection	1. Reduce load if restart failed. 2. Reset the unit manually with the main switch (item D in Figure 3).
Red		
— — — — —	Battery under voltage protection, DC-input voltage too low	Check if DC cables are too long / narrow. Reduce DC cable lengths or use cables with a larger gauge. Loose or corroded connections: Tighten the connections; correct damaged cables immediately. Flat battery: Disconnect the load and recharge the battery
Red, slow blinking		
— — — — —	DC-input voltage too high	Check battery voltage and switch off other chargers (Battery Over Voltage Protection).
Red, fast blinking		
—————	Phase/frequency failure	Make sure AC input frequency matches the Unit output frequency.
Orange		
— — — — —	Grid over/under voltage protection	Make sure AC input is within 90VAC ~ 132VAC
Orange, slow blinking		
— — — — —	Grid over current protection	1. Turn off the load and make sure there is no short circuit at AC OUT. 2. Check the AC input current limit (DIP switches S4, S5 and S6). 3. Reset the unit manually with the main switch.
Orange, fast blinking		

6.4 3-step charge process

The PowerCombi can connect many types of batteries (default setting is Flooded). Parameters can be adjusted, by software, to meet the battery charging characteristics.

The PowerCombi includes an automatic 3-stage charging process: Bulk, Absorb, and Float Charge. The automatic 3-stage charge process provides complete recharging and monitoring of the batteries without damage due to overcharging.

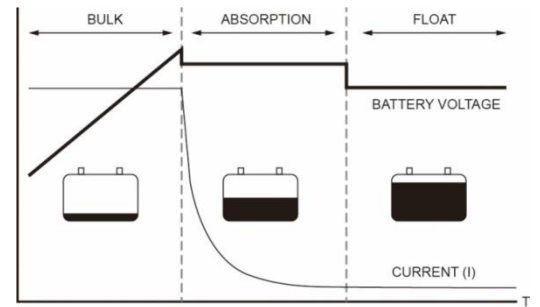

Figure 8: Three step charge system

- **Bulk charging;** the initial stage of charging. While bulk charging, the charger supplies the battery with controlled constant current. The charger will remain in bulk charge until the absorption charge voltage (determined by the Battery Type selection) is achieved and charging time is 0.5~20 hours (configurable, see section 5.2), then switches to absorption charging.
- **Absorption charging;** the second charging stage and begins after the absorption voltage has been reached. Absorption charging provides the batteries with a constant voltage and reduces the DC charging current in order to maintain the absorption voltage setting. Charging for 0.5~10 hours (configurable, see section 5.2), then switches to final charging.
- **Float charging;** the third charging stage occurs at the end of the absorption charging time. While final charging, the charge voltage is reduced to the final charge voltage (determined by the battery type). In this stage, the batteries are kept fully charged and ready if needed by the inverter. The float charging stage reduces battery gassing, minimizes watering requirements (for flooded batteries), and ensures the batteries are maintained at optimum capacity.
- **Temperature compensated charging;** by installing the battery temperature sensor (for Lead Acid batteries only) the charge voltages are automatically adapted for deviating temperatures. When the battery temperature is low, the charge voltage increases. On the other hand, when the battery temperature is high, the charge voltage is decreased. Overcharge and gassing are prevented this way. This will extend the life of your batteries.

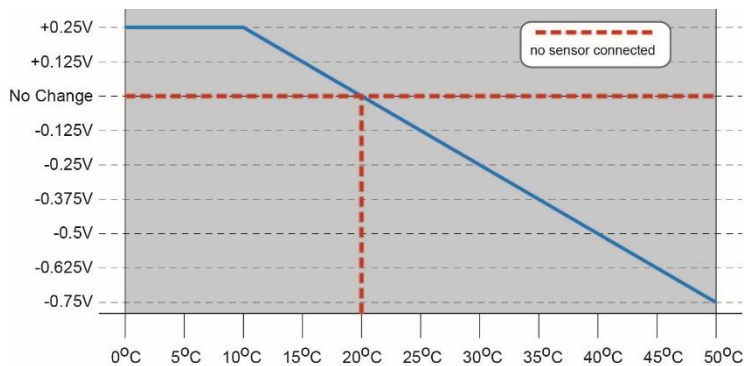

Figure 9 : Temperature compensation using battery temperature sensor

6.5 Protections

- **Overload or short circuit;** while in the inverter mode, the PowerCombi Inverter/Charger will shut down automatically if the overload or short circuit lasts over 3 seconds. The PowerCombi Inverter/Charger will automatically restart. After 4 failed start attempts, the PowerCombi Inverter/Charger shuts down permanently. After the overload short circuit is removed, restart by switching the PowerCombi Inverter/Charger manually off and on with the main switch.
- **High temperature;** if the temperature of the PowerCombi Inverter/Charger exceeds 104°F [40°C], it will reduce power. If it exceeds 140°F [60°C], it will shut down, trigger the status LEDs and optionally a remote alarm. When cooled off, the PowerCombi Inverter/Charger will automatically restart.
- **Under and over voltage;** the AC-input of the PowerCombi Inverter/Charger is, within limits, protected against over and under voltage. See specifications. If the AC-input voltage is out of operating range, the unit will switch to inverter mode, disconnecting both AC inputs and it will switch back if the AC-input voltage is within range again. The DC-input of the PowerCombi Inverter/Charger is also protected against over and under voltage. See specifications. The PowerCombi Inverter/Charger switches off if the DC-input voltage is out of range.
- **Reverse polarity;** an integrated fuse protects the PowerCombi Inverter/Charger if the battery is connected in reverse. Because the internal fuse is non-replaceable, the PowerCombi Inverter/Charger must be returned for repair if the fuse blows.
- **AC Input breaker;** A 30A thermal fuse protects the transfer switch of the PowerCombi Inverter/Charger against overload. If the status LEDs indicate an overload, proceed as follows:
 - Step 1. Turn AC power off and disconnect all loads from the PowerCombi Inverter/Charger.
 - Step 2. Move the main switch to the Off position (○).
 - Step 3. Investigate the cause of failure of the thermal fuse like overload or short-circuits.
 - Step 4. Wait for at least two minutes and then reset the fuse by pushing the button, item G in Figure 3, at the AC side of the PowerCombi Inverter/Charger.
 - Step 5. Connect the PowerCombi Inverter/Charger to the power sources again.
 - Step 6. Turn on the PowerCombi Inverter/Charger.



CAUTION!

The unit is not protected against serious over voltage on the AC input. Make sure AC input is within the range of 90 - 135V_{AC}.

6.6 Maintenance

No specific maintenance to the PowerCombi Inverter/Charger is required. Examine your electrical installation on a regular basis, at least once a year. Defects such as loose connections, damaged wiring etc. must be corrected immediately. If necessary, use a soft clean cloth to clean the PowerCombi Inverter/Charger. Do not use any liquids or corrosive substances, such as solvents, alcohol, petrol or abrasive components.

6.7 Decommissioning

If it is necessary to put the PowerCombi Inverter/Charger out of operation, follow the instructions in order of succession as described below:

Step 1. Turn AC power off.

Step 2. Move the main switch to the Off position (●).

Step 3. Remove the DC fuse(s) and disconnect the batteries.

Step 4. Remove the AC fuse(s) of the AC input and/or disconnect the AC mains.

Step 5. Open the connection compartment of the PowerCombi Inverter/Charger.

Step 6. Check with a suitable voltage meter whether the inputs and the outputs of the PowerCombi Inverter/Charger are voltage free.

Step 7. Disconnect all the wiring.

Now the PowerCombi Inverter/Charger can be demounted in a safe way.

6.8 Storage and transportation

When not installed, store the PowerCombi Inverter/Charger in the original packing, in a dry and dust free environment.

7 TROUBLESHOOTING

For a detailed description of the status LEDs, please refer to section 6.3 on page 18.

If you cannot solve a problem using the fault finding tables, contact your supplier or Mastervolt. Make sure you have the part and serial number at hand.

Malfunction	Possible cause	What to do
No AC output	Short circuit on AC output	Check connected AC load for short circuits
	AC input frequency out of range	Check input frequency.
	Overheating error	Check whether the air flow of the PowerCombi Inverter/Charger is blocked or the ambient temperature is too high. Reduce the connected load and let the PowerCombi Inverter/Charger cool down. As soon as the temperature drops below the factory default threshold, the inverter is powered up automatically or the charger resumes its charge current.
	External breaker (GFCI /RCD) has tripped	Check the external breaker at the AC output (if applied).
	AC Input breaker has tripped	Check the AC input breaker (item G in Figure 3: AC side – exterior).
	Inverter in overload	Check the load connected and disconnect.
	Battery is empty	Recharge battery.
Output voltage too low, charger supplies maximum current	Load connected to the batteries is larger than charger can supply.	Reduce load taken from the batteries.
	Batteries not 100% charged	Measure battery voltage. After some time, this will be higher.
	Wrong setting of the charge voltage	Check settings (see chapter 5).
No charge function	AC input voltage or frequency out of range	Check input voltage. Default AC input voltage range: 90-125VAC
	Charge current limited by Power Sharing Mode	See section 3.4
Charge current too low	Batteries almost fully charged	Nothing, this is normal when the battery is almost fully charged.
	High ambient temperature	Nothing; if ambient temperature is more than the setting limit, the charge current is automatically reduced.
	Charge current limited by Power Sharing Mode	See section 3.4

Malfunction	Possible cause	What to do
Batteries not fully charged	Charge current too low	See "Charge current too low" in this table.
	Current to load is too high	Reduce load taken from the batteries.
	Battery temperature too low	Use the battery temperature sensor.
	Defective or old battery	Check battery and replace if necessary.
	Wrong setting of the charge voltage	Check settings (see chapter 5).
Batteries are discharged too fast	Battery capacity reduced due to wastage or sulfation, stagnation	Charge and recharge a few times, this might help. Check battery and replace if necessary.
Batteries are too warm, gassing	Defective battery (short circuit in cell)	Check battery and replace if necessary.
	Battery temperature too high	Use the battery temperature sensor.
	Charge voltage too high	Check settings (see chapter 5).
All LED indicators are off	Main switch is set to the OFF position	Set the main switch in the ON position
	Main switch is set to REMOTE but no remote present	Set the main switch in the ON position
	The remote switch is off (if applied)	Close the remote operation switch
	DC fuse blown	Replace the fuse
Auxiliary battery is not charged	Auxiliary DC output fuse blown	Replace the fuse (item B in Figure 5)

8 TECHNICAL DATA

8.1 Specifications

	PowerCombi 12V/1200W-50A	PowerCombi 12V/2000W-100A
Product code	36211200	36212000
Specification Inverter		
Nom. battery voltage	12 VDC	12 VDC
Input voltage Range	10.5-16.5 VDC	10.5-16.5 VDC
Switch off voltage high battery	15.5 VDC (1 sec. delay)	15.5 VDC (1 sec. delay)
Switch on voltage high battery	15.0 VDC (5 sec. delay)	15.0 VDC (5 sec. delay)
Switch off voltage low battery	10.0 VDC (3 sec. delay)	10.0 VDC (3 sec. delay)
Switch on voltage low battery	11.5 VDC (5 sec. delay)	11.5 VDC (5 sec. delay)
Input Current (Max)	132 A _{DC}	260A _{DC}
No Load Current	<3.0A@12.5V	<4.0A@12.5V
Standby Current	<0.4A	<0.4A
Cont. power at 77°F [25°C], cos phi 1	1200 W	2000 W
Peak load	101%-115% (1 min) 2400 W (2s)	101%-115% (1 min) 4000 W (2s)
Output voltage	100/110/115/120 VAC (± 3%) – 50/60 Hz (± 0,3 Hz)	100/110/115/120 VAC (± 3%) – 50/60 Hz (± 0,3 Hz)
Max. Efficiency (Full Load)	89%	89%
Output waveform	Pure Sine Wave (THD<5% @ 12.5V/115VAC, linear load)	Pure Sine Wave (THD<5% @ 12.5V/115VAC, linear load)
INV. AC output	12A Max	20A Max
AC Output max total	30A Max	30A Max
Input Protections	Over / Under voltage	Over / Under voltage
AC Output Protection	Overload, Short circuit	Overload, Short circuit
Temperature Protection	Yes	Yes
Battery Temp. Protection	Through temperature sensor (product code 41500700)	Through temperature sensor (product code 41500700)
Technology	High frequency	High frequency
Specification Charger		
Nominal Input	110 VAC, 50/60Hz (± 3 Hz), user-selectable	110 VAC, 50/60Hz (± 3 Hz), user-selectable
Input Voltage range	90-132 VAC	90-132 VAC
Nominal AC input current	8.2A (@110VAC)	16.5A (@110VAC)
Max. Efficiency	>88%	>88%
Power Factor	>0.95	>0.95
Max. Charging Current	50A	100A

	PowerCombi 12V/1200W-50A	PowerCombi 12V/2000W-100A			
Battery Temp. compensation	14mV per °F [-25 mV per °C] (if battery temperature sensor is applied)				
Battery Control (3-stage Battery Chargers); DIP switch adjustable	Battery type				
	Stage	Flooded (default)	GEL	AGM	Custom
	Bulk	14.40V	14.40V	14.40V	14.40V*
	Absorption	14.25V	14.25V	14.25V	14.25V*
Float	13.25V	13.80V	13.80V	13.25V*	
* Adjustable by PowerCombi Remote Control Panel or PowerCombi Interface					
Auxiliary Output Voltage	Same as charge voltage				
Auxiliary Output Current	20A Max		20A Max		
Transfer system specification					
AC Input protection	30A Max (resettable breaker)				
General Specification					
Dimensions hwxwd in inches [mm]	9.9x4.6x15.2 [251x116x386]		9.9x4.6x17.8 [251x116x453]		
Weight in lb [kg]	10 [4.5]		13 [6]		
Protection degree	IP 21				
Operating temperature (see Figure 10)	-4°F to 140°F, derating > 104°F [-20°C to 60°C, derating > 40°C]				
Relative humidity	Max 93%, Non-condensing				
Cooling	Fan				
Power sharing function	Yes (see section 3.4)				
AC IN support mode	Yes (see section 3.4)				
Safety standard	UL458 incl. Supplement SA, UL1741, ABYC A-31				
EMC Standards	Certified FCC Class A				
Options					
Remote control	Dry contacts				
Remote Control Panel	Product code 77010700				
Dry Contact Terminal	By a relay (max 1A)				
MasterBus compatible	Via PowerCombi Interface (product code 77032900)				

Specifications are subject to change without prior notice.

8.2 De-rating Curve

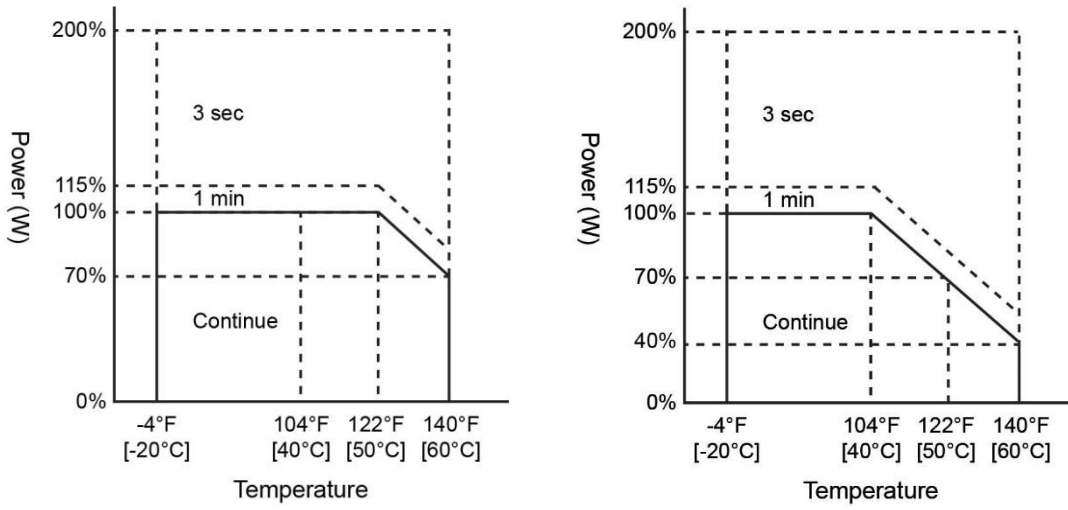

Figure 10 : PowerCombi 1200W (left) and PowerCombi 2000W (right) De-rating Curve

MASTERVOLT

Europe, Middle East & Africa

Customer Service

T: +31 (0) 20 34 22 100
E: info@mastervolt.com

Technical Support

T: +31 (0) 20 34 22 100
E: ts@mastervolt.com

Location & Shipping

Mastervolt
Snijdersbergweg 93
1105 AN Amsterdam
The Netherlands

Americas & Caribbean

Customer Service

T: +1 800 307 6702, Option 1
E: orderentry@marinco.com

Technical Support

T: +1 800 307 6702, Option 2
E: tsusa@mastervolt.com

Location & Shipping

Power Products, LLC
N85 W12545 Westbrook Crossing
Menomonee Falls, Wisconsin 53051
United States

Asia Pacific

Customer Service

T: +64 9 415 7261 Option 1
E: enquiries@bepmarine.com

Technical Support

T: +64 9 415 7261 Option 3
E: technical@bepmarine.com

Location & Shipping

BEP Marine
42 Apollo Drive
Rosedale, Auckland 0632
New Zealand