

MASTERVOLT

THE POWER TO BE INDEPENDENT

MasterBus PowerCombi Interface

Interface from MasterBus to
PowerCombi Inverter/Charger



USER AND INSTALLATION MANUAL

1000015305/02

1 GENERAL INFORMATION

This manual serves as a guideline for the safe and effective operation of the PowerCombi MasterBus Interface. Keep this manual at a secure place!

Warranty

Mastervolt assures the product warranty of the PowerCombi MasterBus Interface during two years after purchase, on the condition that the product is installed and used according to the instructions in this manual. Installation or use not according to these instructions may result in under performance, damage or failure of the product and may void this warranty. The warranty is limited to the cost of repair and/or replacement of the product. Costs of labor or shipping are not covered by this warranty.



CAUTION!

Never remove the identification label.
This will void the warranty.

Liability

Mastervolt can accept no liability for:

- consequential damage due to use of the PowerCombi MasterBus Interface;
- possible errors in the manuals and the results thereof;
- use that is inconsistent with the purpose of the product.

Disclaimer

Our products are subject to continual development and improvement. Therefore, additions or modifications to the products may cause changes to the technical data and functional specifications. No rights can be derived from this document. Please consult our online Terms & Conditions of Sale.

Correct disposal of this product



This product is designed and manufactured with high quality materials and components, which can be recycled and reused.

Please be informed about the local separate collection system for electrical and electronic products.

Please act according to your local rules and do not dispose of your old products with your normal household waste. The correct disposal of your old product will help prevent potential negative consequences to the environment and human health.

2 COMPATIBILITY

The PowerCombi MasterBus Interface supports the following models:

- PowerCombi 12V/1200W-50A 120V – 36211200
- PowerCombi 12V/2000W-100A 120V – 36212000

3 INSTALLATION

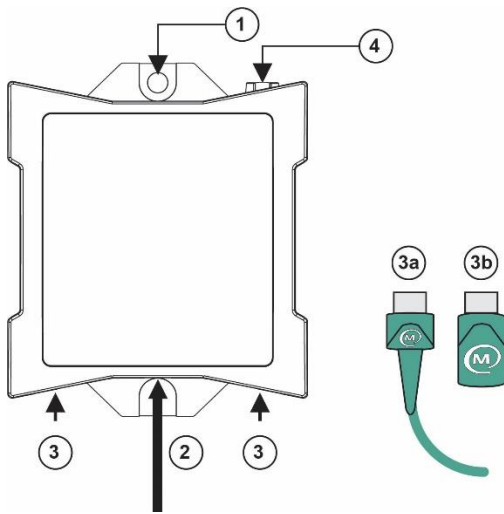

Steps:

1. Mount the PowerCombi MasterBus Interface to any flat surface. The PowerCombi MasterBus Interface comes with a DIN rail mount option. Alternatively, use the two mounting holes (1).
2. Insert the RJ11 cable (included) and connect to the remote port (REMO) of the PowerCombi (2).
3. Adding the PowerCombi MasterBus Interface to the MasterBus network:
 - Disconnect a MasterBus cable (3a) or Terminator (3b) from the closest MasterBus device and connect it to the PowerCombi MasterBus Interface.
 - Connect the new MasterBus cable (included) to the other MasterBus device and then connect to the PowerCombi MasterBus Interface.

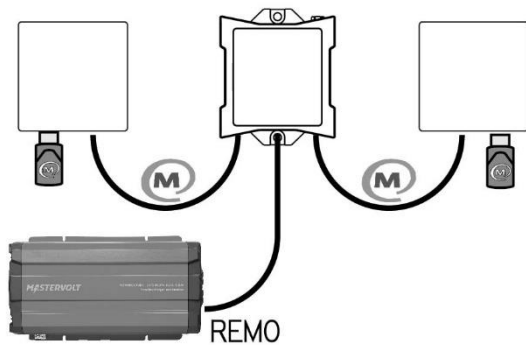

4. A flashing LED (4) indicates that the MasterBus communication is working.
5. When the PowerCombi MasterBus Interface is connected, open MasterAdjust on a Windows laptop or notebook connected to the MasterBus network via a MasterBus USB interface. MasterAdjust is available as free to download software on the Mastervolt website: www.mastervolt.com.

For more information refer to the manual of the PowerCombi.

4 CONFIGURATION

The following table lists the MasterBus monitoring functions as shown in MasterAdjust.

Monitoring	Description	Default	Adjustable range
General			
Device state	The operation mode: Off, Charging, Inverting, Alarm, Power saving, Supporting	<i>Not applicable</i>	(read only)
AC IN Limit	Fuse setting of the AC input	15	3-30
Power button	Button to switch off/on the PowerCombi	On	On, Off
DC IN/OUT			
Charger state	Charger state: Off, Bulk, Absorption, Float	<i>Not applicable</i>	(read only)
Voltage	Battery voltage	<i>Not applicable</i>	(read only)
Current	Battery current (minus is discharging)	<i>Not applicable</i>	(read only)
Temperature	Battery temperature (if not connected: --- °F)	<i>Not applicable</i>	(read only)
AC IN			
Voltage	AC input voltage	<i>Not applicable</i>	(read only)
Current	AC input current	<i>Not applicable</i>	(read only)
AC OUT			
Voltage	AC output voltage	<i>Not applicable</i>	(read only)
Power	AC output power	<i>Not applicable</i>	(read only)

The following table lists the MasterBus alarms with their meaning:

Alarm	Description
DC High voltage	Battery voltage is too high.
DC Low voltage	Battery voltage is too low.
Temperature	Internal temperature of the PowerCombi is too high.
Overload	The loads exceed the nominal inverter power
Device error	Internal PowerCombi error.
AC IN limit	AC input voltage or frequency out of range

The following table shows the PowerCombi configuration settings.

Configuration	Description	Default	Adjustable range
Device			
Language	Language displayed on monitoring device connected to PowerCombi	English	Read-only
Name	Name of the PowerCombi in MasterBus	PowerCombi	Free text with a max. of 12 characters
Type	PowerCombi type	12V/1200W-50A or 12V/2000W-100A	Read-only
Inverter			
Energy save mode	Option to enable Energy save mode	Off (not checked)	Off. On
Frequency	Output frequency	60Hz	60Hz
Voltage	AC voltage	115V	100 - 120
DC low off	Low battery voltage at which the inverter switches off	10.0V / 20.0V	10.00-11.50 (12V) 20.00-23.00 (24V)
DC low on	Low battery inverter switch on voltage at DC Low off alarm	11.5V / 23.0V	10.00-14.50 (12V) 20.00-29.00 (24V)
DC high off	High battery voltage for inverter switch off	15.5V / 31.0V	15.00-16.50 (12V) 30.00-33.00 (24V)
DC high on	High battery voltage for inverter switch to DC High Off alarm	15.0V / 30.0V	13.00-16.50 (12V) 26.00-33.00 (24V)
Charger			
Max charge cur.	Maximum charging current adjustable.	50A / 100A	13-50 (12V/1200W-50A) 25-100 (12V/2000W-100A) 6-25 (24V/1200W-25A) 13-50 (24V/2000W-50A)
Battery type	Select the main battery type.	Flooded (Lead acid)	Flooded, Gel, AGM, User defined
Bulk			
Voltage	Maximum Bulk voltage (adjustable if User Defined).	Flooded: 14.40 / 28.80 Gel: 14.40 / 28.80 AGM: 14.40 / 28.80 User defined: 14.40 / 28.80	12.00-16.00 (12V) 24.00-32.00 (24V) Read-only when battery type is not User defined
Maximum time	Maximum time the bulk phase lasts before the charger changes to absorption.	480min	30-1200 Read-only when battery type is not User defined
Absorption			
Voltage	Absorption voltage (adjustable if User Defined is selected).	14.25V / 28.50V	12.00-16.00 (12V) 24.00-32.00 (24V) Read-only when battery type is not User defined
Maximum time	Maximum time that the charger stays in absorption mode.	240min	30-600
Float settings			
Voltage	Float voltage (adjustable if User Defined).	Flooded: 13.25/26.50 Gel: 13.80/27.60 AGM: 13.80/27.60 User defined: 13.25/26.50	12.00-16.00 (12V) 24.00-32.00 (24V) Read-only when battery type is not User defined
AC IN			
AC IN support	Allow AC support mode option	Off (not checked)	Off. On
DIP Switches	Position of the DIP switches	<i>Not applicable</i>	Read-only

A MasterBus device can be programmed to initiate an action at another connected device. This is very helpful in automation of your system. In MasterBus this is done by means of event-based commands. In the Events tab you can program the PowerCombi to act as an event source. Events which occur during the operation of the PowerCombi will then trigger actions from other products. The following tables list the parameters as shown in MasterAdjust.

Events	Description	Value
Event x source	Event that triggers an action, e.g. Battery low	See <i>Event source</i> list
Event x target	Device that should act, e.g. the generator	System dependent
Event x command	Parameter that must be changed on the target device, e.g. Activate	See command list of the selected device
Event x data	Data is linked to the command	Off, On, Copy, Copy Invert, Toggle

The PowerCombi can be configured as an *event source*. An event source can be used to initiate an *event command* and *event action* by another device that is connected to the MasterBus.

Event source	Description
Power	PowerCombi is switched on
Overload	Loads exceed nominal inverter power
DC Low voltage	Main battery voltage has dropped below Low bat value
Alarm	PowerCombi alarm has been triggered
AC IN	AC input is present

When the PowerCombi is configured as an *event target* by another device, this device can initiate an *event command* and an *event action* to be performed by the PowerCombi.

Event command	Description
Power	Change PowerCombi on/off state

5 TROUBLESHOOTING

Problem	Possible cause	What to do?
PowerCombi cannot be found	Connected device is not set to remote control	Switch the PowerCombi's main switch to position <i>remote</i>
	Error in the wiring	Check the cables
PowerCombi is switched off via interface but still consumes energy	PowerCombi is set to <i>on</i> instead of <i>remote</i>	On the PowerCombi, switch the main switch to position <i>remote</i>
No display function	Display is switched off	Switch on display, refer to display manual
	Error in the wiring.	Check the MasterBus cables
	No powering device available on the MasterBus	With AC power disconnected, the PowerCombi MasterBus Interface gets no power from the MasterBus network. At least one connected MasterBus device should have powering capabilities

Problem	Possible cause	What to do?
Slow or no MasterBus communication	Error in the MasterBus wiring	Check the MasterBus cables
	No terminator at the end(s) of the network	MasterBus needs a terminator on both ends of the network
	MasterBus network is configured as ring network or has T-connections	Ring networks and T-connections are not allowed. Check the connections of the network

6 SPECIFICATIONS

Product code:	77032900
Delivery also includes:	- MasterBus terminator - MasterBus cable 39inch [1m] - RJ11 straight cable 39inch [1m] - User and installation manual
Languages available:	English
Current consumption:	35mA
MasterBus Powering:	No
DIN rail mounting:	Yes, DIN rail 1.2inch [30mm]
Protection degree:	IP 21
Weight:	0.15lb [70g]
Dimensions:	2.6 x 3.1 x 1.3inch [66 x 78 x 32mm]

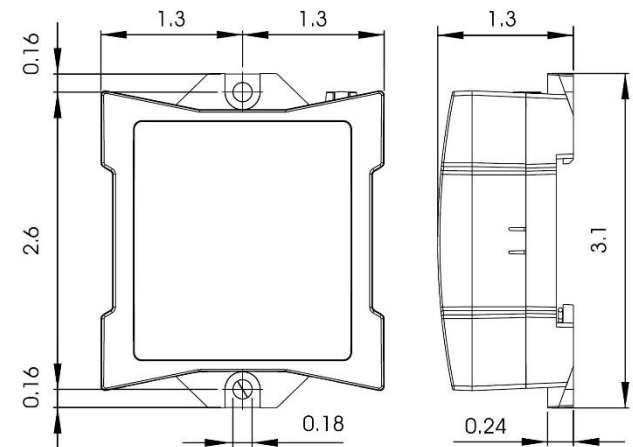

Dimensions in inches

Copyright © 2020 Mastervolt. All rights reserved.

MASTERVOLT
THE POWER TO BE INDEPENDENT

Europe, Middle East & Africa
The Netherlands
Customer Service
T: +31(0)203422100
E: info@
mastervolt.com

Technical Support
T: +31(0)203422100
E: ts@
mastervolt.com

Americas & Caribbean
United States
Customer Service
T: +1 800 307 6702
E: orderentry@
marinco.com

Technical Support
T: +1 800 307 6702
E: tsusa@
mastervolt.com

Asia Pacific
New Zealand
Customer Service
T: +64 9 415 7261
E: enquiries@
bepmarine.com
Technical Support
T: +64 9 415 7261
E: technical@
bepmarine.com